



Nursery Supplies

Product Catalog



Table of Contents

Blow-Molded Containers Custom™ & Olympian™	4
Blow- Molded Containers Grip-Lip™ & Econo-Grip™	5-6
Pressure Formed	7
Printing, Hot Stamping, and Labels	8
NSI & PI Injection Molded	9-10
Large Vacuum Formed	11
Propagation Liners & Trays, Dec-Grow®	12
Accelerator®	13

www.nurserysupplies.com



Locations

1415 Orchard Drive
Chambersburg, PA 17201
Ph: 800-523-8972
Fax: 888-223-4876

2050 Avenue "A"
Kissimmee, FL 34758
Ph: 800-523-8972
Fax: 866-653-4394

1613 N. Bolton Street
Jacksonville, TX 75766
Ph: 800-523-8972

Miscellaneous Container Information:

- Listed volume sizes are slightly smaller than measured volumes to allow for the natural variances in the plastic molding process.
- Shipping tower counts may vary and are continually being updated.
- Sizes, weights, capacities, product, and specifications subject to change without notice.
- For detailed information on ANLA standards and trade sizes or to join ANLA visit their website at www.americanhort.org
- Every effort is made to ensure the accuracy of data contained within this brochure; NSI does not assume any liability for errors or omissions.
- Contact Nursery Supplies to confirm availability.
- All containers are measured ID, +/- 1/8"
- Some products may require minimum order quantities
- CCY = Containers per cubic yard of soil

Nursery Supplies, Inc. Trademarks:

- Accelerator®
- AGS Above Ground System®
- Grip Lip®
- Dec-Grow®
- Classic®
- Lerio®
- Nursery Supplies, Inc.® (Name& Mark)
- Olympian
- Econo-Grip

OUR PRODUCTS ARE 100% RECYCLABLE.

Blow-Molded Containers Classic Line

- Custom= Lightweight
- Olympian= Mid-weight
- Available in color for additional fee.
- Label Compatible.
- One year quality guarantee



Product ID	Trade Size	Top Dia. (in.)	Height (in.)	Gallons	Quarts	Liters	CCY	Stack	Tower
C100	SP#4	4 3/4	4 5/8	0.21	0.84	0.80	957	140	24,640
C200	SP#5	6	6	0.46	1.84	1.74	438	125	14,750
C275	#1	6 5/8	5 1/2	0.55	2.18	2.07	369	100	9,200
C300S	#1	6 1/2	6 1/2	0.63	2.50	2.37	324	106	10,388
010	#1	6 5/8	6 1/2	0.71	2.84	2.72	281	84	8,232
C300	#1	6 3/8	7 1/4	0.73	2.94	2.78	275	100	9,200
C350	Sm. Mum Pan	8	5 1/8	0.77	3.06	2.90	264	130	8,320
C400	#1	7 3/4	7	1.00	4.00	3.79	202	92	6,440
C550	Lg. Mum Pan	9	6 1/8	1.21	4.84	4.58	167	97	4,850
C600	#2	9	8 1/2	1.50	6.00	5.68	135	105	5,250
020	#2	8 1/2	8	1.44	5.75	5.44	140	61	3,294
C700	#2	8 3/4	8 1/2	1.73	6.92	6.55	116	86	4,128
C900	#2	9 1/2	9 1/8	1.94	7.75	7.33	104	83	3,818
C1000A	#2	9 1/2	8 5/8	2.00	8.00	7.57	101	90	4,140
C1000S	#2 Squat	10 1/8	7 1/2	1.95	7.78	7.36	104	75	2,700
C1200S	#2+ Squat	11	7 1/2	2.32	9.28	8.78	87	60	1,920
C1000	10 Foliage	10 1/8	9 1/8	2.25	9.00	8.52	90	70	2,520
C1200	#3	11	9 1/2	3.00	12.00	11.36	67	56	1,792
030	True #3	10 1/2	9 7/8	3.00	11.62	11.00	69	47	1,692
C1600S	#3 Squat	11 7/8	7 7/8	2.87	11.47	10.85	70	47	1,316
C1600	#5	11 7/8	10 1/8	3.58	14.32	13.55	57	47	1,316
C2000	#5	11 7/8	11	3.84	15.37	14.55	53	44	1,232
B5	#5	11 3/4	10 1/2	4.11	16.44	15.56	49	45	1,260
C2100	#5 Squat	14	9 7/8	5.17	20.68	19.58	39	31	837
C2800	#7	14	11 1/2	6.08	24.32	23.02	34	31	837
C4000S	#7 Squat	15	12 1/2	7.49	29.97	28.36	27	21	672
B7S	#7 Squat	16 1/2	11	7.74	30.96	29.31	26	30	480
C4000	#10	15 3/4	15	9.16	36.64	34.68	23	27	432
C6900S	#10 Squat	18 3/8	12 1/8	10.66	42.66	40.37	19	19	285
C6900	#15	18 3/8	15 1/8	13.35	53.40	50.54	15	18	270
B15	#15	17 3/4	16	13.50	54.00	51.13	15	18	324
C10000S	#20 Squat	23 3/4	13 1/8	19.50	78.00	73.82	11	14	168
C10000	#25	23 3/4	18 1/8	27.17	108.68	102.89	7	10	150
B25	#25	23	17 1/4	25.14	100.56	95.20	8	10	200
C18000	#45	30	20 1/8	45.28	181.12	171.44	4	5	50
C26000	#65	30 3/4	23 1/8	60.67	242.68	229.70	3	5	50

Blow-Molded Containers Grip-Lip® & Econo-Grip®

- Grip-Lip (GL)= Standard Weight, used as socket
- Econo-Grip (EG)= Economy Weight, used as liner
- Pot-In-Pot
- Rope Handles
- Available in color
- Label, Printing, and Hot Stamping Compatible
- One year quality guarantee



Product ID	Trade Size	Top Dia. (in.)	Height (in.)	Gallons	Quarts	Liters	CCY	Stack	Tower
GL/EG1200	#3	9 5/8	9 1/2	2.70	10.81	10.23	75	44	1,584
GL/EG1400	#5 Egg Can	9 5/8	12	3.28	13.12	12.42	62	40	1,440
GL/EG1600	#5	10 7/8	10 3/8	3.58	14.32	13.55	57	35	980
GL/EG2000	#5	10 7/8	11 1/8	3.93	15.72	14.88	51	35	980
GL/EG2800S	#5 Squat	13 3/4	10	5.56	22.25	21.06	36	20	640
GL/EG2800	#7	13 3/4	12	6.08	24.32	23.02	34	20	640
GL/EG4000	#10	14 1/4	14 1/4	9.16	36.64	34.68	23	19	342
GL/EG6900S	#10 Squat	17 1/4	12 1/8	10.69	42.75	40.46	19	17	170
GL/EG6000	#10 Tall	14 1/4	17 1/4	10.26	41.03	38.83	20	19	342
GL/EG6900	#15	17 1/4	15 1/8	13.19	52.76	49.93	16	17	170
GL/EG8000S	#15 Squat	19 1/2	12	13.66	54.66	51.72	15	18	144
GL/EG6900T	#15 Tall	17 1/4	17 1/8	14.49	57.96	54.86	14	16	160
GL/EG8000	#20	19 1/2	17	19.50	78.00	73.82	11	16	128
GL/EG10000S	#20 Squat	22 3/4	13 1/8	20.51	82.03	77.63	10	14	168

Minimum order quantities may apply

Blow-Molded Containers Grip-Lip® & Econo-Grip®

Pot-in-Pot

Product ID	Trade Size	Approx Caliper	Liner Pot
GL2800	#7	3/4" - 1	EG2800/2800CU
GL4000	#10	1"	EG4000
GL6900	#15	1 1/4" - 2	EG6900/6900BXL
GL10000	#25	2"-2 1/2"	EG10000/10000BXL
C18000	#45	3"	C18000

*Additional sizes available

Minimum order quantities may apply

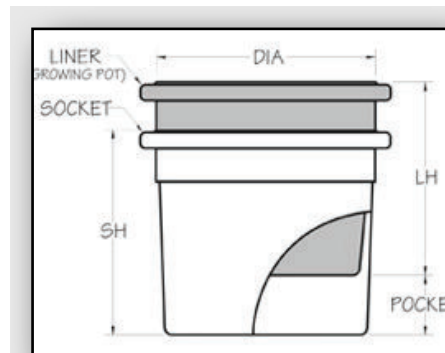

Above-Ground-Systems

Product ID	Trade Size	Top Dia. (in)	Dia	Height (in.)	Stack	Tower
AGS 2800	#7	15 1/4"	19 1/2"	12 1/2"	9	144
AGS 6900	#15	17 1/4"	22 3/4"	17 1/4"	6	108

Minimum order quantities may apply



Rope Handles

Product ID	Trade Size	Top Dia. (in.)	Height (in.)	Gallons	Quarts	Liters	CCY	Stack	Tower
GL4000	#10	14 1/4	14 1/4	9.16	36.64	34.68	23	19	342
GL6900S	#10 Squat	17 1/4	12 1/8	10.68	42.75	40.46	19	17	170
GL6000	#10 Tall	14 1/4	17 1/4	10.25	41.03	38.83	20	19	342
GL6900	#15	17 1/4	15 1/8	13.19	52.76	49.93	16	17	170
GL8000S	#15 Squat	19 1/2	12	13.66	54.66	51.72	15	18	144
GL6900T	#15 Tall	17 1/4	17 1/8	14.49	57.96	54.86	14	16	160

*Additional sizes available

Minimum order quantities may apply

Pressure Formed

- Economical
- Automation friendly
- Strong & resilient
- Co-extruded colors
- True gallon sizes
- Label and printing compatible
- Available in color for an additional fee
- One year quality guarantee



Product ID	Trade Size	Top Dia. (in)	Height (in.)	Gallons	Quarts	Liters	CCY	Stack	Tower
PF250**	#1	6 1/8	6 1/8	0.63	2.50	2.37	324	93	8,556
PF310S**	#1	6 1/8	6 1/2	0.63	2.50	2.37	306	80	7,360
PF310**	#1	6 1/8	7	0.65	2.60	2.46	298	80	7,360
PF400**	True #1	7 1/2	7 1/8	1.00	4.00	3.79	202	85	5,440
PF550**	Lg. Mum Pan	9 1/2	6	1.55	6.20	5.87	131	91	3,276
PF600**	#2	8 1/2	8 1/2	1.50	6.00	5.68	135	90	4,140
PF700**	#2	9	9	1.72	6.88	6.51	117	36	3,956
PF800**	True #2	8 7/8	9 3/8	2.00	8.00	7.57	101	87	4,002
PF1000**	10 Foliage	9 5/8	9 1/8	2.25	9.00	8.52	90	89	3,204
PF1200**	True #3	10 1/2	9 3/8	3.00	12.00	11.36	68	71	2,272
PF1200S**	#3 Squat	10 1/2	7 3/4	2.45	9.80	9.27	82	72	2,304
PF1200T	#3	9 3/4	11 3/4	3.00	12.00	11.35	67	63	1,260
PF1400	#5 Egg Can	10 1/8	12	3.58	14.32	13.55	57	43	1,548
PF1600	#5	11 1/2	10	3.58	14.32	13.55	57	38	1,368
PF2000	#5	11 1/2	11 1/4	4.00	16.00	15.14	51	38	1,368

**Available with Tag Slots

Minimum order quantities may apply

Printing, Hot-Stamping, & Labels

Branding moves products, and NSI is your branding expert. We offer our blow molded, thermoformed and injection molded containers in many standard colors or select a custom color to meet your marketing requirements. Ensure your customer knows you year after year by having a recognizable brand. Our weather tested and customer-proven inks can be printed on a color container with your specific design. NSI offers a one color hot-stamp option to imprint your logo multiple times around the container. Our graphics department can even render your design before the manufacturing process to ensure satisfaction. NSI can also be your source for barcode labeling. Our labels are resistant to water, chemical and smudging. Contact your Regional Sales Manager for further details.



NSI Injection Molded

- Injection Molded Pots
- Tier Stacking
- Tags slots available in select sizes
- Available in color for additional fee
- Label, hot stamp, and printing
- One year quality guarantee



Product ID	Trade Size	Top Dia. (in.)	Height (in.)	Gallons	Quarts	Liters	CCY	Stack	Tower
NS300**	#1	6	6 7/8	0.65	2.60	2.45	311	55	6,490
NS400**	True #1	7 1/2	7	1.00	4.00	3.79	202	60	3,840
NS600**	#2	8 1/2	8 1/2	1.73	6.92	6.55	117	48	2,880
NS800**	True #2	8 7/8	9 3/8	2.00	8.00	7.57	101	42	2,016
NS-3**	#3	10 3/16	9	2.54	10.12	9.58	80	50	1,800
NS1200**	True #3	10 9/16	9 1/2	3.00	12.00	11.36	68	42	1,512
NS-5S**	#5 Squat	11 1/4	9 7/8	3.58	14.32	13.55	57	41	1,148
NS1400**	#5	10 1/4	12 1/4	3.58	14.32	13.55	57	37	1,332
NS-7S	#7 Squat	14	11 1/4	6.20	24.78	23.45	33	24	576
NS-7T	#7 Tall	12	14 1/8	6.20	24.78	23.45	33	8	288
NS-10S	#10 Squat	14 3/4	11 1/2	7.97	31.88	30.17	26	13	208
NS-15S	#15 Squat	17 1/2	15 3/8	12.07	48.28	45.69	17	12	180

**Available with Tag Slots

Minimum order quantities may apply

PI Injection Molded



- Strong & Rigid
- Tier Stacking
- Available in color for additional fee
- Label, hotstamp and printing compatible
- Economical Injection products
- One year quality guarantee

Product ID	Trade Size	Top Dia. (in)	Height (in.)	Gallons	Quarts	Liters	CCY	Tower
PC-1C (LW)	#1	6	6 3/4	0.63	2.50	2.39	321	7,488
PC-1D	#1	6	6 3/4	0.71	2.84	2.69	285	4,664
PC-1H	#1	6	7	0.69	2.76	2.62	293	5,808
PC-2	#2	8 3/8	8 3/8	1.78	7.12	6.74	114	2,800
PC-1000**	#3	9 1/4	9	2.25	9.00	8.52	90	1,908
PC-3	#3	10	9 1/4	2.77	11.08	10.49	73	1,656
PC-3S	#3 Squat	10 1/2	8	2.53	10.12	9.58	80	1,872
CA-5	Egg Can	10	11 3/4	3.62	14.48	13.70	56	1,140
PC-5S	#5 Squat	10 3/4	10 1/2	4.08	16.32	15.45	50	960
PC-5 Special**	#5 Trade	10 3/8	11 1/2	3.23	13	12.3	59	1,755
PC-NW5S	#5 Squat	11	10 1/2	3.74	14.96	14.16	55	1,350
PC-6S	#6 Squat	12 1/4	9 1/4	4.36	17.44	16.51	47	840
PC-7S	#7 Squat	14	11 1/4	6.92	27.68	26.20	30	576
PC-10	#10	15 1/4	14 1/2	10.27	41.08	38.88	20	450
PC-10S	#10 Squat	16 1/4	12	9.51	38.04	36.00	22	432
PC-15	#15	14 1/2	18	11.10	44.40	42.02	19	324
PC-15S	#15 Squat	18 1/4	13 1/2	13.47	53.88	50.99	15	360
PC-15T Special	#15 Tall	14 1/4	16 5/8	9.17	36.68	34.71	22	630
PC-15TT	#15 Tall	14 1/4	17 1/4	10.69	42.75	40.46	19	400
FP-6	6"	6 1/4	5 3/8	0.49	1.96	1.86	413	8,400
FP-8	8"	8 3/4	7 3/4	1.47	5.88	5.57	138	3,750
FP-10	10"	10 1/2	9 1/2	2.64	10.56	9.99	77	2,640

**Available with Tag Slots

Minimum order quantities may apply

Large Vacuum Formed

- Large Vacuum Formed Pots are available in a wide range of sizes. These pots have exceptional strength and durability. They're ideal for trees, shrubs, and other long cycle crops. They can withstand heavy weight under root and soil pressure, as well as retain durability in high heat and sunlight.
- One year quality guarantee



Product ID	Trade Size	Top Dia. (in)	Height (in.)	Gallons	Quarts	Liters	CCY	Stack
SW35	#35	24	18	30.16	120.62	114.15	7	1
SW45	#45	28	19	42.81	171.25	162.06	5	1
SW65	#65	30	21	53.47	213.87	202.40	4	1
LER65	#65	30	21	52.03	208.12	196.96	4	1
SW65S	#65 Squat	35	18	63.78	255.12	241.44	3	1
SW95	#95/100	36	24	88.48	353.94	334.95	2	1
LER95	#95/100	36	24 3/8	93.28	373.12	353.11	2	1
SW100S	#95/100 Squat	42	18 1/4	98.08	392.31	371.27	2	1
LER150	#150	42	26 1/4	133.09	532.34	503.79	2	1
SW200	#200	48	26 1/2	186.08	744.31	704.38	1	1
LER300	#300	58	26	259.70	1038.81	983.08	1	1

Minimum order quantities may apply

Propagation Liner Trays



- Space saving square liners are designed to maximize cost saving strategies for many types of crops. The liners are durable and light weight. They also have fluted sides for community watering. Ideal for annuals, foliage, and woody ornamentals.
- One year quality guarantee

Product ID	Style	Width	Length	Stack	Tower
PT3x6	Propagation Insert 18 Cavity	18 3/8	9 3/16	100	4,000
PT4x8	Propagation Insert 32 Cavity	18 3/8	9 3/16	100	4,000
F1717	Plastic Flat	17	17	60	400
F1818	Plastic Flat	18 7/8	18 7/8	25	400

Minimum order quantities may apply

Dec-Grow®

- The Dec-Grow® line of decorative containers is strong enough for the toughest field use, yet beautiful enough to look perfectly at home on any retailer's shelf or customer's patio.
- One year quality guarantee



Product ID	Trade Size	Top Dia. (in)	Height (in.)	Gallons	Quarts	Liters	CCY	Stack	Tower
#10 DG	#2+	9 7/8	8 3/4	2.12	8.48	8.03	96	45	1,440
#12 DG	#5	11 7/8	10 3/4	3.78	15.12	14.31	54	36	720

Minimum order quantities may apply

Accelerator® Air Root Pruning System



- The Accelerator® air root pruning system is an all natural way to help grow a better plant, from propagation to in-ground planting the patented root enhancement technology ensures stronger roots and higher quality plants. These containers produce much larger trees in the same time as conventional container products, the accelerated growth creates a cost-per-tree that is less than traditional methods.

- The vertical corrugations to guide the root tips to air pruning slots located along the side wall. This results in a denser, more uniform root mass, and eliminates root circling.

- More roots means more nutrients, when roots come in contact with air the roots will automatically be pruned and send a signal back to the plant to order for fresh new roots to grow, which means the new roots will be spreading through fresh patches of nutrients in turn enhancing growth on your plant.

- Accelerator® grown plants survive longer in inclement weather due to a healthier denser rootmass. This will also increase shelf life which will extend your selling period.

- One year quality guarantee

Product ID	Trade Size	Top Dia. (In.)	Height (in.)	Gallons	Quarts	Liters	CCY	Stack	Tower
AP-3	#3	12	8	2.68	10.72	10.14	75	41	1,148
AP-10	#10	18	12	9.35	37.40	35.40	22	20	300
AP-15	#15	18	15 1/2	12.00	48.00	45.42	17	19	285
AP-30	#25	24	15 3/4	22.50	90.00	85.17	9	9	162
AP-45	#45	30	18	41.90	167.60	158.84	5	6	108
AP-65	#65	30	22	52.50	210.00	198.77	4	5	100

Minimum order quantities may apply

Listing By Trade

Product ID	Type	Trade Size	Top Dia.(in.)	Height(in.)	Gallons	Quarts	Liters	CCY
C100	BM	SP#4	4 3/4	4 5/8	0.21	0.84	0.80	957
C200	BM	SP#5	6	6	0.46	1.84	1.74	438
C275	BM	#1	6 5/8	5 1/2	0.55	2.18	2.07	369
PC-1C (LW)	INJ	#1	6	6 3/4	0.63	2.50	2.39	321
PF250	PF	#1	6 1/8	6 1/8	0.63	2.50	2.37	324
PF310S	PF	#1	6 1/8	6 1/2	0.63	2.50	2.37	306
C300S	BM	#1	6 1/2	6 1/2	0.63	2.50	2.37	324
NS300	INJ	#1	6	6 7/8	0.65	2.60	2.45	311
PF310	PF	#1	6 1/8	7	0.65	2.60	2.46	298
PC-1H	INJ	#1	6	7	0.69	2.76	2.62	293
PC-1D	INJ	#1	6	6 3/4	0.71	2.84	2.69	285
010	BM	#1	6 5/8	6 1/2	0.71	2.84	2.72	281
C300	BM	#1	6 3/8	7 1/4	0.73	2.94	2.78	275
C400	BM	#1	7 3/4	7	1.00	4.00	3.79	202
NS400	INJ	True #1	7 1/2	7	1.00	4.00	3.79	202
PF400	PF	True #1	7 1/2	7 1/8	1.00	4.00	3.79	202
C350	BM	Sm. Mum Pan	8	5 1/8	0.77	3.06	2.90	264
C550	BM	Lg. Mum Pan	9	6 1/8	1.21	4.84	4.58	167
PF550	PF	Lg. Mum Pan	9 1/2	6	1.55	6.20	5.87	131
C1000S	BM	#2 Squat	10 1/8	7 1/2	1.95	7.78	7.36	104
020	BM	#2	8 1/2	8	1.44	5.75	5.44	140
PF600	PF	#2	8 1/2	8 1/2	1.50	6.00	5.68	135
C600	BM	#2	9	8 1/2	1.50	6.00	5.68	135
C1000A	BM	#2	9 1/2	8 5/8	2.00	8.00	7.57	101
C700	BM	#2	8 3/4	8 1/2	1.73	6.92	6.55	116
PF700	PF	#2	9	9	1.72	6.88	6.51	117
NS800	INJ	True #2	8 7/8	9 3/8	2.00	8.00	7.57	101
PF800	PF	True #2	8 7/8	9 3/8	2.00	8.00	7.57	101
C1200S	BM	#2+ Squat	11	7 1/2	2.32	9.28	8.78	87
PF1000	PF	10 Foliage	9 5/8	9 1/8	2.25	9.00	8.52	90
C1000	BM	10 Foliage	10 1/8	9 1/8	2.25	9.00	8.52	90
PF1200S	PF	#3 Squat	10 1/2	7 3/4	2.45	9.80	9.27	82
PC-3S	INJ	#3 Squat	10 1/2	8	2.53	10.12	9.58	80
C1600S	BM	#3 Squat	11 7/8	7 7/8	2.87	11.47	10.85	70
PC-1000	INJ	#3	9 1/4	9	2.25	9.00	8.52	90
NS-3	INJ	#3	10 1/5	9	2.54	10.12	9.58	80
GL/EG1200	BM	#3	9 5/8	9 1/2	2.70	10.81	10.23	75
PC-3	INJ	#3	10	9 1/4	2.77	11.08	10.49	73
PF1200T	PF	#3	9 3/4	11 3/4	3.00	12.00	11.35	67
C1200	BM	#3	11	9 1/2	3.00	12.00	11.36	67
030	BM	True #3	10 1/2	9 7/8	3.00	11.62	11.00	69
PF1200	PF	True #3	10 1/2	9 3/8	3.00	12.00	11.36	68
NS1200	INJ	True #3	10 9/16	9 1/2	3.00	12.00	11.36	68
PC-5S	INJ	#5 Squat	10 3/4	10 1/2	4.08	16.32	15.45	50
NS-5S	INJ	#5 Squat	11 1/4	9 7/8	3.58	14.32	13.55	57
PC-NW5S	INJ	#5 Squat	11	10 1/2	3.74	14.96	14.16	55
C2100	BM	#5 Squat	14	9 7/8	5.17	20.68	19.58	39
GL/EG2800S	BM	#5 Squat	13 3/4	10	5.56	22.25	21.06	36
PC-5 Spcl	INJ	#5	10 3/8	11 1/2	3.23	13.00	12.30	63
NS1400	INJ	#5	10 1/4	12 1/4	3.58	14.32	13.55	57
GL/EG1600	BM	#5	10 7/8	10 3/8	3.58	14.32	13.55	57
PF1600	PF	#5	11 1/2	10	3.58	14.32	13.55	57
C1600	BM	#5	11 7/8	10 1/8	3.58	14.32	13.55	57

Listing By Trade

Product ID	Type	Trade Size	Top Dia.(in.)	Height(in.)	Gallons	Quarts	Liters	CCY
C2000	BM	#5	11 7/8	11	3.84	15.37	14.55	53
GL/EG2000	BM	#5	10 7/8	11 1/8	3.93	15.72	14.88	51
PF2000	PF	#5	11 1/2	11 1/4	4.00	16.00	15.14	51
B5	BM	#5	11 3/4	10 1/2	4.11	16.44	15.56	49
GL/EG1400	BM	#5 Egg Can	9 5/8	12	3.28	13.12	12.42	62
PF1400	PF	#5 Egg Can	10 1/8	12	3.58	14.32	13.55	57
CA-5	INJ	#5 Egg Can	10	11 3/4	3.62	14.48	13.70	56
PC-6S	INJ	#6 Squat	12 1/4	9 1/4	4.36	17.44	16.51	47
NS-7S	INJ	#7 Squat	14	11 1/4	6.20	24.78	23.45	33
PC-7S	INJ	#7 Squat	14	11 1/4	6.92	27.68	26.20	30
C4000S	BM	#7 Squat	15	12 1/2	7.49	29.97	28.36	27
B7S	INJ	#7 Squat	16 1/2	11	7.74	30.96	29.31	26
GL/EG2800	BM	#7	13 3/4	12	6.08	24.32	23.02	34
C2800	BM	#7	14	11 1/2	6.08	24.32	23.02	34
NS-7T	INJ	#7 Tall	12	14 1/8	6.20	24.78	23.45	33
NS-10S	INJ	#10 Squat	14 3/4	11 1/2	7.97	31.88	30.17	26
PC-10S	INJ	#10 Squat	16 1/4	12	9.51	38.04	36.00	22
C6900S	BM	#10 Squat	18 3/8	12 1/8	10.66	42.66	40.37	19
GL/EG6900S	BM	#10 Squat	17 1/4	12 1/8	10.69	42.75	40.46	19
GL/EG4000	BM	#10	14 1/4	14 1/4	9.16	36.64	34.68	23
C4000	BM	#10	15 3/4	15	9.16	36.64	34.68	23
PC-10	INJ	#10	15 1/4	14 1/2	10.27	41.08	38.88	20
GL/EG6000	BM	#10 Tall	14 1/4	17 1/4	10.26	41.03	38.83	20
NS-15S	INJ	#15 Squat	17 1/2	15 3/8	12.07	48.28	45.69	17
PC-15S	INJ	#15 Squat	18 1/4	13 1/2	13.47	53.88	50.99	15
GL/EG8000S	BM	#15 Squat	19 1/2	12	13.66	54.66	51.72	15
PC-15	INJ	#15	14 1/2	18	11.10	44.40	42.02	19
GL/EG6900	BM	#15	17 1/4	15 1/8	13.19	52.76	49.93	16
C6900	BM	#15	18 3/8	15 1/8	13.35	53.40	50.54	15
B15	INJ	#15	17 3/4	16	13.50	54.00	51.13	15
PC-15T Spcl	INJ	#15 Tall	14 1/4	16 5/8	9.17	36.68	34.71	22
PC-15TT	INJ	#15 Tall	14 1/4	17 1/4	10.69	42.75	40.46	19
GL/EG6900T	BM	#15 Tall	17 1/4	17 1/8	14.49	57.96	54.86	14
C10000S	BM	#20 Squat	23 3/4	13 1/8	19.50	78.00	73.82	11
GL/EG10000S	BM	#20 Squat	22 3/4	13 1/8	20.51	82.03	77.63	10
GL/EG8000	BM	#20	19 1/2	17	19.50	78.00	73.82	11
GL/EG8000T	BM	#20 Tall	19 1/2	19 5/8	21.64	86.56	81.92	10
B25	INJ	#25	23	17 1/4	25.14	100.56	95.20	8
C10000	BM	#25	23 3/4	18 1/8	27.17	108.68	102.89	7
GL/EG10000	BM	#25	22 3/4	18 1/8	27.59	110.36	104.44	8
SW35	VAC	#35	24	18	30.16	120.62	114.15	7
SW45	VAC	#45	28	19	42.81	171.25	162.06	5
C18000	BM	#45	30	20 1/8	45.28	181.12	171.44	4
LER65	VAC	#65	30	21	52.03	208.12	196.96	4
SW65	VAC	#65	30	21	53.47	213.87	202.40	4
C26000	BM	#65	30 3/4	23 1/8	60.67	242.68	229.70	3
SW65S	VAC	#65 Squat	35	18	63.78	255.12	241.44	3
SW100S	VAC	#95/100	42	18 1/4	98.08	392.31	371.27	2
SW95	VAC	#95/100	36	24	88.48	353.94	334.95	2
LER95	VAC	#95/100	36	24 3/8	93.28	373.12	353.11	2
LER150	VAC	#150	42	26 1/4	133.09	532.34	503.79	2
SW200	VAC	#200	48	26 1/2	186.08	744.31	704.38	1
LER300	VAC	#300	58	26	259.70	1,038.81	983.08	1

Visit us at “nurserysupplies.com”

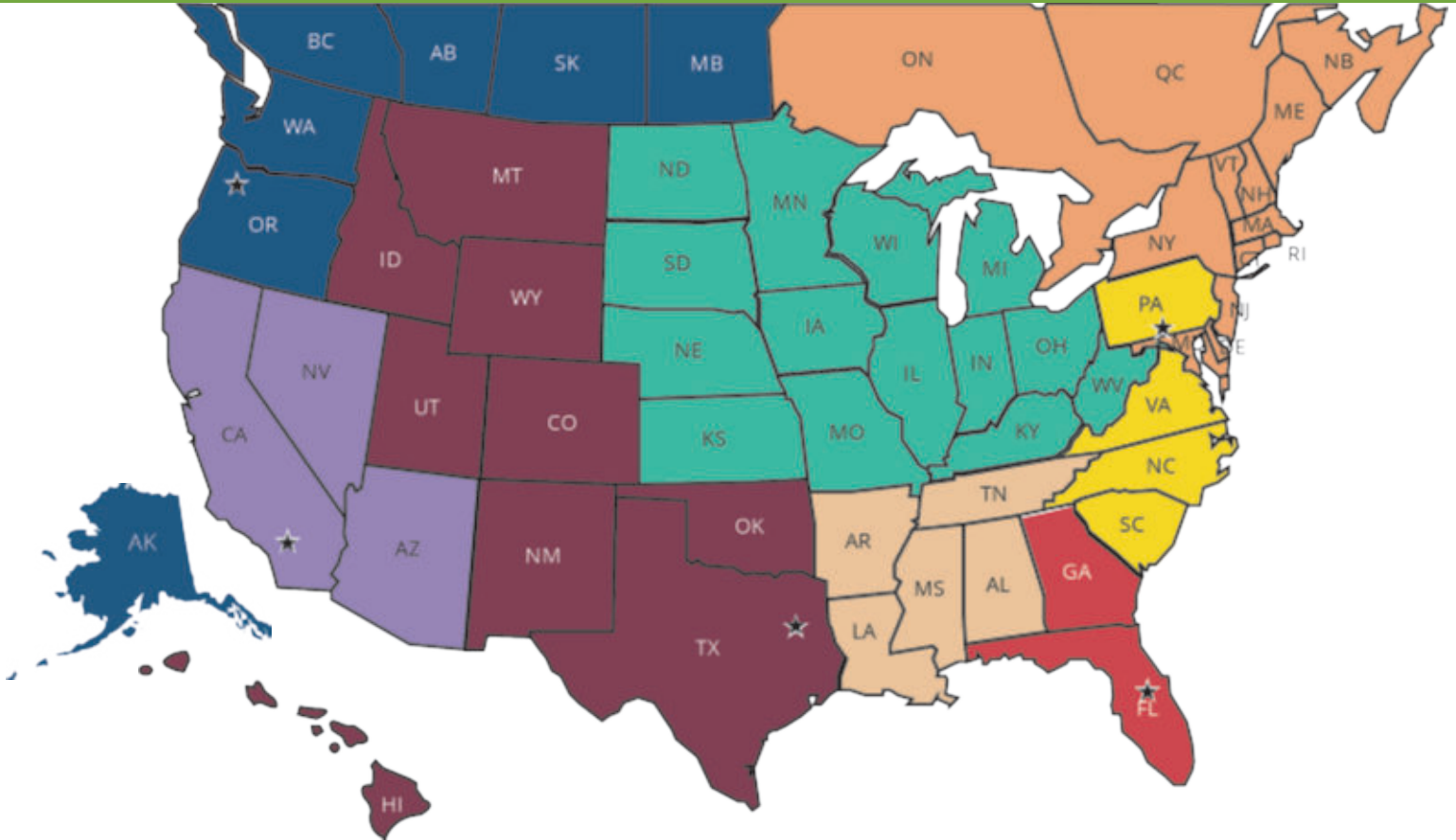

ROB SUMMERS
Sr. VP of Sales
robs@nurserysupplies.com
614-214-4278



COURTNEY LEWIS-BORTS
Western Sales
AK, AB, AZ, BC, CA, MB, NV, OR, SK, WA
clewis@nurserysupplies.com
503-507-2173



RICK REMLING
Range States & HI
TX, CO, ID, MT, NM, OK, UT, WY, HI
rremling@nurserysupplies.com
210-241-7802



HEATHER CANNON
North Central Sales
IL, IN, IA, KS, KY, MI, MN, MO, NE, ND,
OH, SD, WV, WI
hcannon@nurserysupplies.com
330-447-3202



ANDY ZIMLICH
South Central Sales
AL, AR, LA, MS, TN
azimlich@nurserysupplies.com
251-402-4896



MICHELLE BOUDREAU
Eastern Sales
NC, PA, SC, VA
michelleb@nurserysupplies.com
717-262-8796



ROB RODRIGUEZ
Northeast Sales
CT, DE, DC, ME, MD, MA, NB, NH, NJ, NY, ON,
QC, RI, VT
robr@nurserysupplies.com
207-671-3167

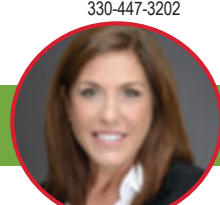

CATHY WOJTAS
Southeastern Sales
FL, GA
cwojtas@nurserysupplies.com
407-751-8737